



Marine & Offshore

SOLUTION GUIDE

Edition 1/21, valid from 08/2021



A Rolls-Royce
solution

PIONEERING THE POWER THAT MATTERS.

We at Rolls-Royce provide world-class power solutions and complete life-cycle support under our product and solution brand **mtu**. Fully utilizing the potential of digitalization and electrification, we strive to develop climate-neutral drive and power generation solutions that are even cleaner and smarter and thus provide answers to the challenges posed by climate change and the rapidly growing societal demands for energy and mobility. We deliver and service comprehensive, powerful and reliable systems, based on both gas and diesel engines, as well as electrified hybrid systems.

A solution provider

mtu systems power the most modern yachts, the strongest tugboats and the biggest land vehicles and provide energy for the world's most important mission-critical applications. With advanced solutions such as microgrids we integrate renewable energies and manage the power needs of our customers.

For over 110 years we have provided innovative solutions for our customers – meeting even the most demanding drive and power requirements. Our products and services span a wide range of applications and power needs, with both standard and customized options.

An expert in technology

mtu products are known for cutting-edge innovation and technological leadership. That same spirit of innovation inspires our sustainability efforts. Our focus is on developing and implementing system solutions that both maximize efficiency and reduce emissions – which in turn helps to reduce our impact on the environment.

A passionate and reliable partner

We at Rolls-Royce spend every day working together with our customers, to deliver engines, systems and complete life-cycle solutions that best fit their needs. We understand that each application is different and has its own specific demands. Our engineers embrace the challenge of finding the perfect solution for your unique power requirements. Every step of the way – from project planning, through design, delivery and commissioning; to the lifetime care of your equipment – we are dedicated to helping you get the most from your **mtu** investment.





CONTENTS

Selection guideline

Marine and offshore supply & service	06
Offshore exploration & production	08

Power range

Power range marine and offshore supply & service	10
Power range offshore exploration & production	14

Rating philosophy

16

Power definition

17

Explanation engine and genset designation

18

New product introduction

20

Engines and gensets overview

Series 60	28
Series 2000	30
Series 4000	32
Series 1163	34
Series 8000	35
Genset 4000	36

Engines and gensets marine and supply & service

Diesel/gas engines for mechanic propulsion	40
Engines and gensets for on-board power generation and electric-propulsion – 50 Hz & 60 Hz	46

Engines and gensets for exploration & production

Engines and gensets for offshore power generation – 50 Hz & 60 Hz	54
---	----

Emission reduction technologies

SCR solutions	60
The new Series 4000 M05	62

Systems solutions and automation systems

System expertise	66
Combined propulsion solutions	68
Standardized and system solutions genoline	70
Marine gensets	72
Offshore generator sets	74
SmartBridge	76
mtu Callosum - integrated ship automation system	78
Standardized propulsion automation systems:	
– BlueVision NewGeneration	80
– bluevision	85

Systems solutions offshore exploration & production

ATEX Zone 2 (IIB T3 Gc)	86
Redundant controller for fire pump drive systems	88

Digital solutions

90

Parts & Service

Complete lifecycle solutions	94
ValueCare	97
Service network	100

Exhaust emissions

IMO	102
US EPA	104
EU 95	105
Abbreviations	107

Conversion table

111

Selection guideline

MARINE AND OFFSHORE
SUPPLY & SERVICE

Application group >		1A	1B	1D	1DS
Mechanical propulsion engines					
Yacht	Planing			■	■
	Semi planing			■	■
	Small displ.		■	■	■
	Large displ. > 120 ft.	■	■	■	■
Cargo ships & tankers	Inland freighters	■			
	Coastal ships	■			
	Sea-river ships	■			
Passenger ships	Tourist boats	■	■		
	Passenger ferries		■		
	Cabin cruisers ships	■	■		
RoPax ferries	Double-ended ferries	■	■		
	Fast ferries < 50 m	■	■		
	Fast ferries > 50 m		■		
Tugs & push boats	Tow & push boats	■			
	Harbour tugs	■	■		
	Coastal tugs	■			
	Escort tugs	■	■		
Offshore vessels & crew boats	Crew boats	■	■		
	Offshore supply ves.	■	■		
	Anchor handl. tugs	■	■		
	Pilot boats	■	■		
	Trawler (fishing ves.)	■	■		
	Firefighting ves.	■	■	■	
	Rescue vessels	■	■	■	
	Research vess.	■	■	■	
	Dredgers	■	■		
	Cable laying ves.	■			

The guideline on page 6 - 7 gives a rough overview which application groups can be considered for which type of vessel or business model. To allocate which application group suits your demands best, the intended annual usage and the expected load profile have to be considered.

Application group >		1A	1B	1D	1DS
Mechanical propulsion engines					
Marine naval vessels	Fast attack crafts			■	■
	Corvettes			■	■
	Frigates and Destroyers		■	■	■
	Amphibious crafts		■	■	■
	Large amphibious and support vessels	■	■	■	
	Mine countermeasure vessels			■	
Patrol boats	Small patrol crafts		■	■	■
	Coastal patrol crafts	■	■	■	■
	Large patrol vessels > 120 ft.	■	■	■	■

Application group >		3A/3B/3C	3A/3B/3C
Power generation and diesel-electric propulsion		50 Hz	60 Hz
	On-board powergen	■	■
	Diesel-electric propulsion	■	■
	Emergency powergen	■	■

3C application is available and common for P-engines and emergency for offshore.

Selection guideline

OFFSHORE EXPLORATION &
PRODUCTION

Diesel engines for

- Heavy lift vessel
 - Diving support vessel
 - Pipe-laying vessel
 - Cable-laying vessel
 - Subsea support vessel
 - Well intervention vessel
 - Accommodation vessel
 - Drill ship
 - Wind converter platform
 - Fixed platform
 - Tension-leg platform
- Jack-up rig
 - Spar-type platform
 - Normally unmanned installation (NUI)
 - Conductor support system
 - Compliant power
 - FLNG
 - Semi-submersible
 - FPSO
 - Windfarm substation platforms

Diesel engines for power generation

Power generation - constant speed

Application group >	3A	3B	3C
Power generation	50/60Hz	50/60Hz	50/60Hz
Power generation	■	■	■
Electric firepump drives		■	■
Electric drilling drives	■	■	

The guideline above gives a rough overview which application groups can be considered for which type of vessel or business model. To allocate which application group suits your demands best, the intended annual usage and the expected load profile have to be considered.



Power range

MARINE AND OFFSHORE
SUPPLY & SERVICE

Main propulsion:

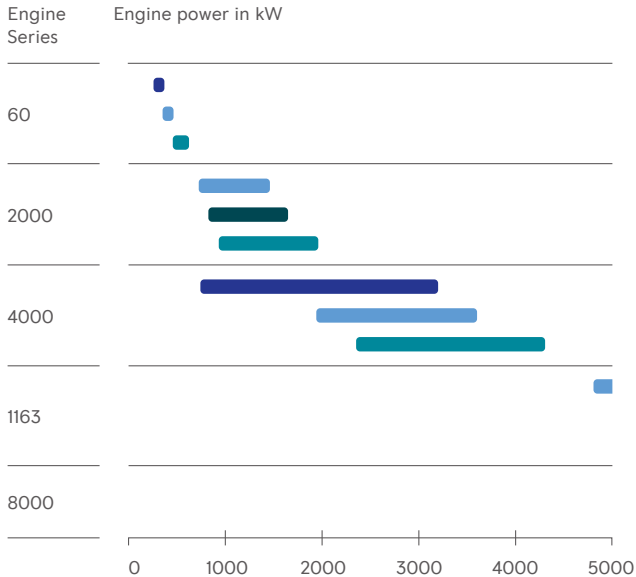

Engine power in kW

Engines	1A	1B	1D	1DS
60	261 – 373	354 – 447	–	466 – 615
2000	–	720 – 1440	810 – 1630	932 – 1939
4000	746 – 3200	1920 – 3600	–	2340 – 4300
1163	–	4800 – 6000	5200 – 6500	5920 – 7400
8000	–	7280 – 9100	–	8000 – 10000

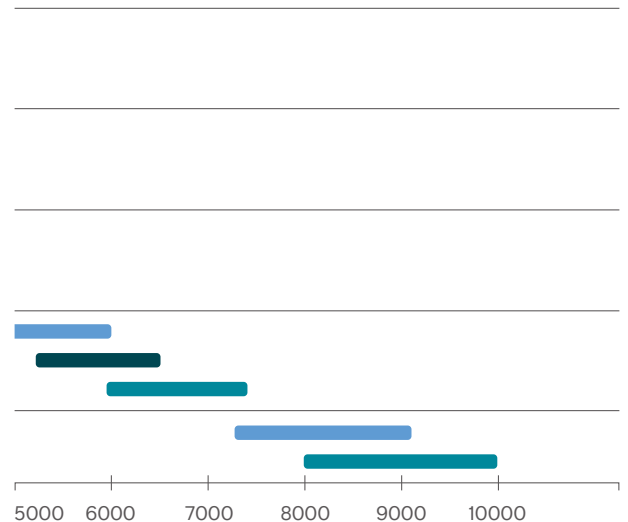
**1A** Engines for vessels w/ unrestricted continuous operation

Average load: 70 - 90% of rated power; Rating definition: ICFN, fuel stop; Typical annual usage: unrestricted*

1B Engines for fast vessels with high load factors

Average load: 60 - 80% of rated power; Rating definition: ICFN, fuel stop; Typical annual usage: 5000 hours*

1D Engines for fast vessels w/ intermittent load factors

Average load: ≤ 60% of rated power; Rating definition: ICFN, fuel stop; Typical annual usage: 3000 hours*

1DS Engines for fast vessels with low load factors

Average load: ≤ 60% of rated power; Rating definition: ICFN, fuel stop; Typical annual usage: 1500 hours*

* Application groups (page 6-9) only indicate which **mtu** engine suits your demands best. For your type of vessel, you can also choose engines from other application groups than stated in the selection guideline. Please note: 1A, 1B and 1D ratings are overload capable to 110% (ICXN) for factory acceptance test, but limited to 100% for operation. 1DS ratings are not overload capable at all.

Power range

MARINE AND OFFSHORE
SUPPLY & SERVICEMarine on-board power generation, diesel-electric drives
and generator sets:

Engine Series Engine power in kW

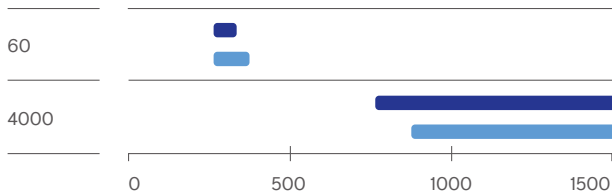

Engine power in kW

Engines	3A/3B	3A/3B
Frequency	50 Hz	60 Hz
60	271 - 322	271 - 370
4000	760 - 2600	895 - 3200

Genset power in kW*

Gensets	3A/3B	3A/3B
Frequency	50 Hz	60 Hz
MG 4000	720 - 1690	850 - 3072

* alternator efficiency of 96% considered, excluding parasitic losses

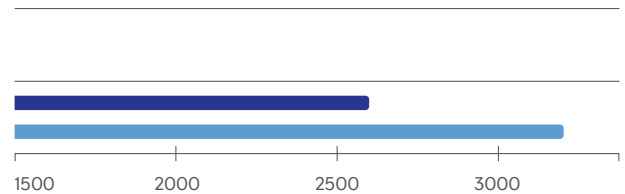
**3A/3B** Engines for onboard power generation and diesel-electric drive

Continuous operation 50 Hz;
 Rating definition: ICXN, 10% overload capability
 Continuous operation 60 Hz;
 Rating definition: ICXN, 10% overload capability

Application groups (page 6-9) only indicate which **mtu** engine suits your demands best. For your type of vessel, you can also choose engines from other application groups than stated in the selection guideline.

Power range

OFFSHORE EXPLORATION &
PRODUCTION

Engines and gensets for power generation:

Engine Series Engine power in kW

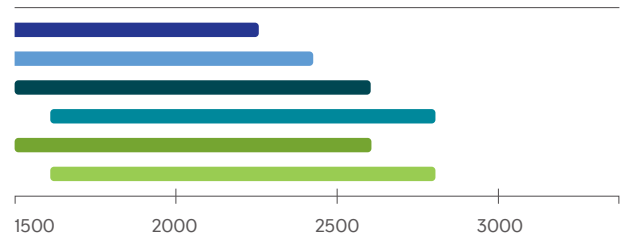
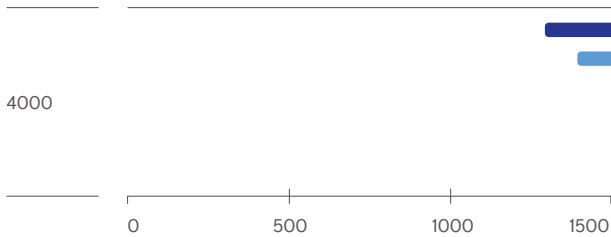

Engine power in kW

Engines	3A	3A	3B	3B	3C	3C
Frequency	50 HZ	60 HZ	50 HZ	60 HZ	50 HZ	60 HZ
4000	1350- 2245	1455- 2425	1560- 2600	1680- 2800	1560- 2600	1680- 2800

Gensets	3A	3A	3B	3B	3C	3C
Frequency	50 Hz	60 Hz	50 Hz	60 Hz	50 Hz	60 Hz
PP 4000	1295- 2155	1395- 2330	1500- 2500	1615- 2690	1500- 2500	1615- 2690

* alternator efficiency of 96% considered, excluding parasitic losses

Application groups (page 6-9) only indicate which **mtu** engine suits your demands best. For your type of vessel, you can also choose engines from other application groups than stated in the selection guideline.

3A/3 B/3C	Engines for power generation, electric fire-pump drives and emergency power – constant speed
3A	Continuous power
50 Hz	Continuous operation power, unrestricted Rating definition: ICXN, 10% overload capability
60 Hz	Continuous operation power, unrestricted; Rating definition: ICXN, 10% overload capability
3B	Prime power
50 Hz	Continuous operation with variable load Rating definition: ICXN, 10% overload capability
60 Hz	Continuous operation with variable load; Rating definition: ICXN, 10% overload capability
3C	Prime power limited
50 Hz	Standby operation with variable load Rating definition: ICXN, 10% overload capability
60 Hz	Standby operation with variable load Rating definition: ICXN, 10% overload capability

RATING PHILOSOPHY

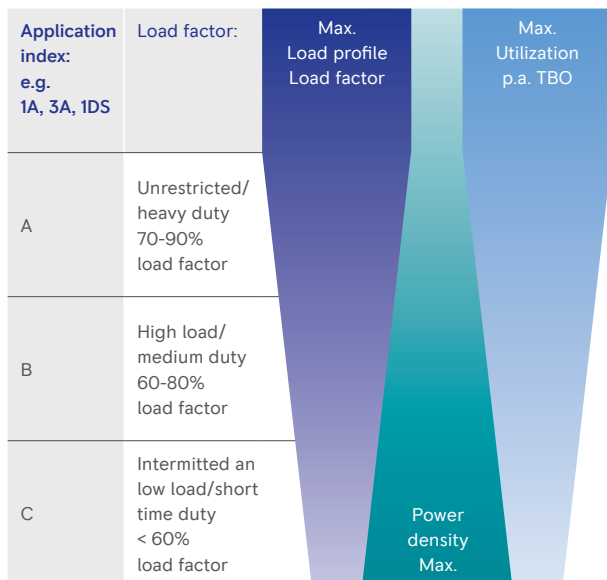

schematic diagram

We are working hard to meet and even exceed the increasing demands of ship owners and operators for cost-effective and eco-friendly solutions. One example is the engine TBO (Time Between Overhauls) which we optimize on the basis of field data analysis and close inspection of engines and components that have already proven their reliability in field operation. Depending on the analysis results, we extend maintenance and TBO intervals keeping safe operation assured.

We offer product lines specifically tailored to customer requirements. Some are laid out for high power density with ideal power-to-weight-ratios (application groups C, D and DS). Other product lines are specifically configured to achieve maximum service life at lower power densities. These are suitable for applications involving high load factors and runtimes up to 8,000 hours per year (application groups A and B).

POWER DEFINITION

The rated power of diesel and gas engines stated in this sales program corresponds to ISO 3046-1:2002 (E) and ISO 15550:2002 (E). The power produced at the flywheel will be within the tolerance of 3% - according to ISO 15550:2002 (E) - up to 25°C (77°F) combustion air temperature measured at the air cleaner inlet and up to 25°C (77°F) sea or raw water temperature measured at the seawater pump suction inlet, unless other values mentioned explicitly.

ICFN = ISO standard (continuous) fuel stop power
 ICXN = ISO standard (continuous) power exceedable by 10% (ratings also apply to ISO 8665 and SAE J1228 standard conditions)

Barometric pressure: 1000 mbar
 Site altitude above sea level: 100 m
 Fuel specification for diesel: EN 590 to ASTM D 975-00
 (Fuel consumption [with all pumps] in accordance with ISO 3046 [except Series 60], values stated for IMO certification.)

General reference conditions for diesel engines and generator sets:

- Intake air temperature 25°C
- Sea water temperature 25°C
- Charge air coolant inlet temperature 45°C up to 65°C without derating

All engines are designed and built according to classification requirements, certificate on request.

Classification with:

- Unrestricted service for engines with 10% overload capacity
- Restricted service for engines without overload capacity

EXPLANATION OF THE ENGINE DESIGNATION

Series 2000 / 4000 / 1163 / 8000 – Example

16 V 4000 M7 3 L

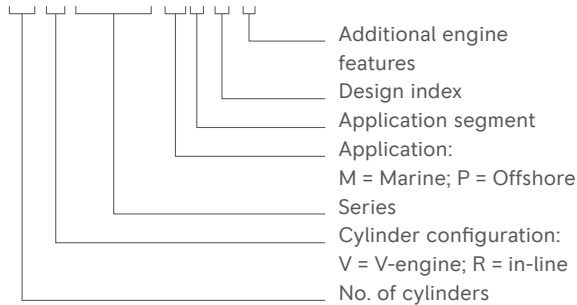

EXPLANATION OF THE GENSET DESIGNATION

Generator sets with Series 4000 – Example

MG 08 V 4000 A 3

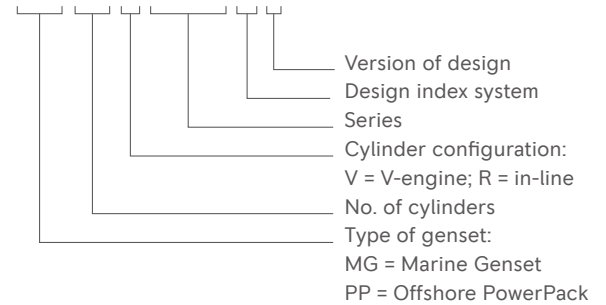

Turbocharged engines/gensets with

Separate-circuit charge-air cooling	60 / 4000 P / 1163
Split-circuit charge-air cooling	2000 M / 4000 M / 8000 M

Additional engine/gensets features

Power uprated	L
Gas Fuel	N
Power/speed reduced	R
Frequency	A or F (50 Hz); B or S (60 Hz)

New product introduction

HIGH-PERFORMANCE 2000 M96X
GETS A POWER BOOST TO MORE
THAN 2,000 HORSEPOWER.

Series 12V 2000 M96X



OTAM



Viking

up to
1472 kW
or over
2000 MHP

The **mtu** high-performance yacht engine gets a power upgrade as the output of the 12-cylinder Series 2000 M96 engine is increased from 1,432 kW to 1,472 kW, equivalent to more than 2,000 horsepower. Its proven acceleration characteristics, excellent maneuverability and quiet, smooth operation make the engine especially suited to luxury yachts and leisure fishing boats.

Since its debut in 2015, the IMO-Tier-II and EPA-Tier-3Rec.-certified Series 2000 M96 has been a reliable, efficient engine for yachts.

The engine is also supported by Premium Yacht Service, a global service program for yacht customers. This ensures the boat owner gets fast, reliable support throughout the entire service life of the engine.

New product introduction

HYBRID SYSTEMS FOR YACHTS.
TAKE YOUR LEISURE TO THE
NEXT LEVEL.

Make the most of your yachting experience with an Hybrid PropulsionPack. Not only does hybrid power reduce on-board noise levels, emissions and vibrations, it also improves efficiency, dynamics and comfort.

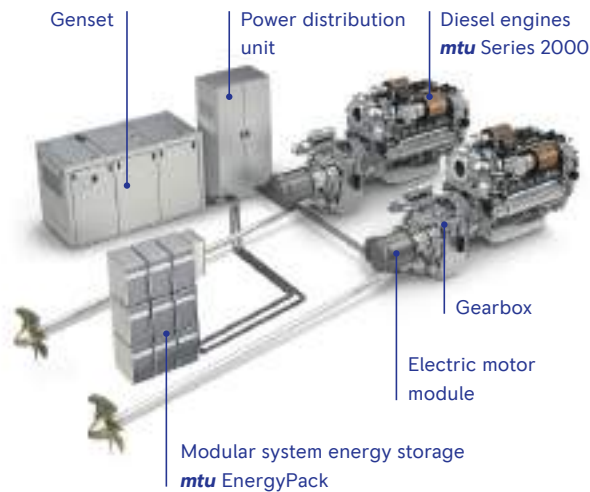
**Powerful**

Great maneuverability,
e-power assisted
propulsion

**Clean**

Meeting the newest
emission regulations

**Comfortable**

Silent, vibration-free
operation

**Reliable**

Optimized maintenance
and operation costs

The components for onboard power and propulsion are modular and scalable. Each hybrid system can be individually designed to meet your requirements.

Enjoy the benefits of silent but highly efficient electric propulsion, exhaust emission-free anchoring – no smell, no smoke, no noise – emission-free maneuvering in harbor areas, and an all-round environmentally friendly system.

Select the hybrid system for your yachting experience:

Comfort hybrid

You can already enjoy silent and emission-free cruising, maneuvering and on-board power with our entry solution. Comfort hybrid is configured with small-sized batteries, small electric motors and small diesel engines. Even with small sized batteries, emission free anchoring is assured.

Premium hybrid

Savor long periods of silent on-board power and long battery-powered excursions. Premium hybrid is configured with medium or large batteries, medium or large electric motors and medium diesel engines. The batteries allow silent cruising for a long time, overnight anchoring is also no problem. The top speed of your vessel can optionally be boosted with battery power depending on propeller design.

Sport hybrid

Raise the maximum speed and agility of your yacht with the speed boost and enjoy silent maneuvering in harbors. Sport hybrid is configured with small batteries, medium electric motors and medium diesel engines. The overall system is designed to offer you the perfect ratio of weight, power and hybrid capabilities.

Series 4000 DS

THE PROOFEN ONE.

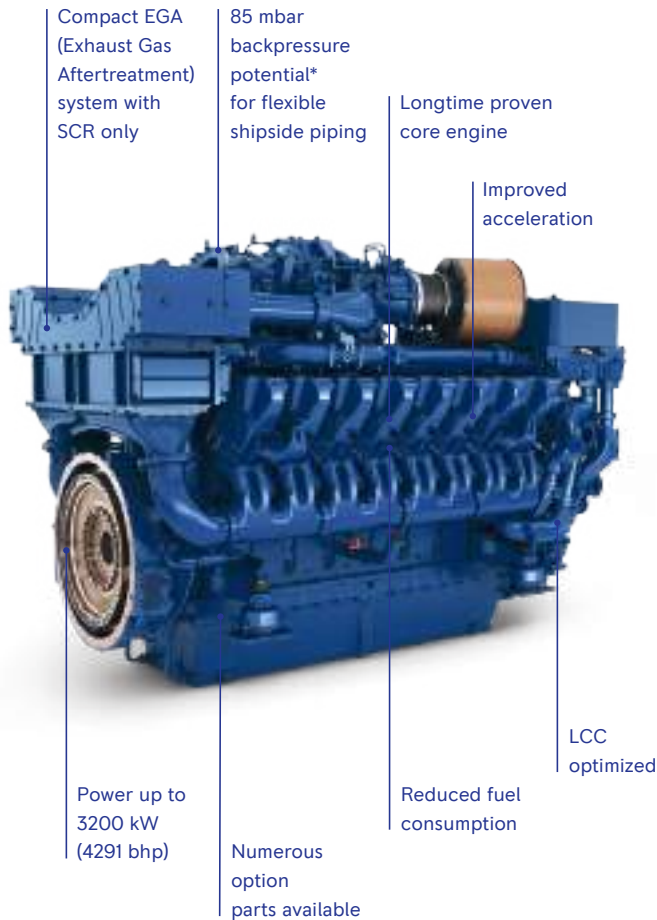

*after SCR-System

up to
3200 KW
(4291 BHP)

Our Series 4000 M05 for commercial marine applications is the latest marine engine of the powerful Series 4000 family. When designing the Series 4000 M05 we kept three topics always in our mind: Lifecycle costs, performance and ease of maintenance.

We used our legendary IRONMEN engines as a basis but finetuned it with high attention to detail to maximize durability, performance and efficiency. Only SCR is needed to fulfill IMO III and EPA Tier 4 emissions regulations.

We also help customers to design and integrate the engine/ SCR combination into their vessel design.

SERIES 4000
over
200M KW
power for marine and
offshore applications
SINCE 1996

ENGINES OVERVIEW



SERIES 60

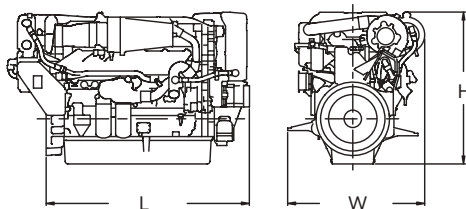

Marine and offshore supply & service

Engine	Displacem. total	Dimensions, max.	Mass, max.
Cylinder config.: 6 cyl./ in-line	l (cu in)	LxWxH mm (in)	(dry) kg (lbs.)
S60	14.0 (855)	1850x1035x1160 (73x41x46)	1633 (3600)

External heat exchanger version as standard, optional engine mounted.

SERIES 2000

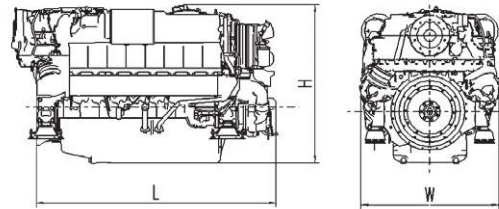

Marine and offshore supply & service

Engine	Displacem. total	Dimensions, max.	Mass, max. TEN/EB
Cylinder config.: 90°V	l (cu in)	LxWxH mm (in)	(dry) kg (lbs.)
10V 2000 M86/96	22.3 (1361)	1604x1165x1347 (63x46x53)	2305 (5082)
12V 2000 M86/96*	26.8 (1635)	1812x1293x1414 (71x46x53)	2810 (6195)
12V 2000 M87/97**	26.8 (1635)	n.a. x1515x2119*** (n.a. x60x83)***	n.a. (n.a.)
16V 2000 M86/96	35.7 (2179)	2258x1293x1453 (89x51x57)	3450 (7606)
16V 2000 M87/97**	35.7 (2179)	3272x1515x2158*** (129x60x85)***	4560*** (10053)***

* mit SRG SAE1

** with additional exhaust gas aftertreatment

*** without insulation of exhaust gas aftertreatment

Marine and offshore supply & service

Engine	Displacem. total	Dimensions, max.	Mass, max. TEN
Cylinder config.: 90°V	l (cu in)	LxWxH mm (in)	(dry) kg (lbs.)
8V 2000 M72/84/93/94	17.9 (1093)	1379x1130x1200 (54x44x47)	1970 (4343)
10V 2000 M72	22.3 (1361)	1544x1130x1230 (61x44x48)	2230 (4916)
12V 2000 M72	26.8 (1635)	1869x1293x1364 (74x51x54)	2780 (6129)
16V 2000 M72	35.7 (2179)	2287x1293x1404 (90x51x55)	3337 (7357)

Engine mounted heat exchanger as standard.

SERIES 4000

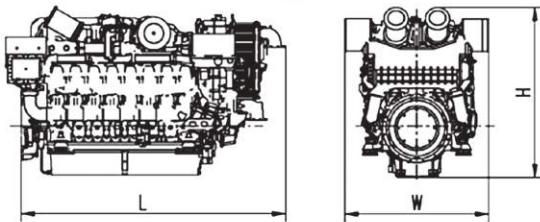

Marine and offshore supply & service

Standard stroke (190 mm)

Engine	Displacem. total	Dimensions, max.	Mass, max.
Cylinder config.: 90°V	l (cu in)	LxWxH mm (in)	(dry) kg (lbs.)
12V 4000 M73/93	51.7 (3155)	2870x1850x2185 (113x73x86)	8410 (18541)
16V 4000 M73/93	69.0 (4210)	3510x1850x2185 (138x73x86)	9890 (21803)
20V 4000 M73/93	86.2 (5260)	4040x1470x2440 (159x58x96)	12900 (28439)

Engine mounted heat exchanger as standard.

Marine and offshore supply & service

Long stroke (210 mm)

Engine	Displacem. total	Dimensions, max.	Mass, max.
Cylinder config.: 90°V	l (cu in)	LxWxH mm (in)	(dry) kg (lbs.)
8V 4000 M23/24/33/53/54/63	38.2 (2331)	2386x1615x1972 (94x64x78)	5710 (12588)
8V 4000 M55RN	38.2 (2331)	2050 x 1820 x 2100 (81x72x83)	6100 (13448)
12V 4000 M23/33/53/63/24/34/54/64/35/65	57.2 (3491)	2750x1793x2370 (108x71x93)	8000 (17637)
16V 4000 M23/33/43/53/63/24/34/54/64/25/35/65	76.3 (4656)	3270x1570x2370 (129x62x93)	9460 (20856)
16V 4000 M55RN	76.3 (4656)	3233x1820x2100 (127x72x83)	9555 (21065)

Engine mounted heat exchanger as standard, external heat exchanger version as option.

Offshore exploration & production

Long stroke (210 mm)

Engine	Displacem. total	Dimensions, max.	Mass, max.
Cylinder config.: 90°V	l (cu in)	LxWxH mm (in)	(dry) kg (lbs.)
12V 4000 P63/83	57.2 (3491)	2530x1590x2065 (100x63x81)	7300 (16093)
16V 4000 P63/83	76.3 (4656)	3000x1590x2065 (118x63x81)	8800 (19400)
20V 4000 P63/83	95.4 (5822)	3470x1590x2065 (137x63x81)	10680 (23545)

External heat exchanger version as standard.

SERIES 1163

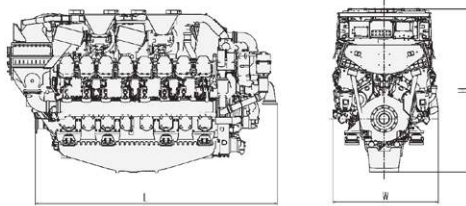

Marine and offshore supply & service

Engine	Displacem. total	Dimensions, max.	Mass, max.
Cylinder config.: 60°V	l (cu in)	LxWxH mm (in)	(dry) kg (lbs.)
16V 1163	186.1 (11357)	4687x1918x3040 (185x76x120)	20590 (45393)
20V 1163	232.7 (14200)	5353x1918x3040 (211x76x120)	25000 (55116)

External heat exchanger version as standard.

SERIES 8000

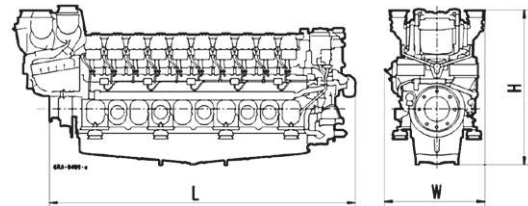

Marine and offshore supply & service

Engine	Displacem. total	Dimensions, max.	Mass, max.
Cylinder config.: 48°V	l (cu in)	LxWxH mm (in)	(dry) kg (lbs.)
16V 8000	278 (16965)	5698x2040x3375 (224x80x133)	42000 (92594)
20V 8000	347.4 (21200)	6645x2040x3375 (262x80x133)	49600 (109348)

External heat exchanger version as standard.

SERIES 4000 GENSET

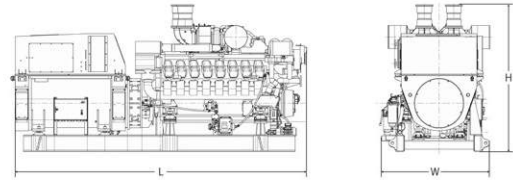

Marine and offshore supply & service

Long stroke (210 mm)

Genset type	Displacem. total	Dimensions, max.	Mass, max.
	l (cu in)	LxWxH mm (in)	(dry) kg (lbs.)
MG08V 4000 M23/24/33	38.2 (2331)	4300x1825 x 2000 (169x72x79)	11000 (24251)
MG12V 4000 M23/24/33/34	57.2 (3491)	5200x1965x2285 (205x77x90)	14000 – 17000 (30865 – 37479)
MG16V 4000 M23/24/33/34/43	76.3 (4656)	5800x1965x2285 (228x77x90)	17500 – 21500 (40786 – 47400)

External heat exchanger version as standard, optional engine mounted.

Offshore exploration & production

Long stroke (210 mm)

Genset type	Displacem. total	Dimensions, max.	Mass, max.
	l (cu in)	LxWxH mm (in)	(dry) kg (lbs.)
PP12V4000A3 P63*/83	57.2 (3491)	4850x1950x2450 (191x77x96)	14500 (31970)
PP16V4000A1/3 P63/83	76.3 (4656)	5720x1950x2450 (225x77x96)	18500 (40786)
PP20V4000A1/3 P63/83	95.4 (5822)	6950x1950x2450 (274x77x96)	24300 (53575)

P engines only available with external heat exchanger. Same will be applicable for M05 if added!

DIESEL/GAS ENGINES FOR MECHANIC PROPULSION



Diesel/gas engines for mechanic propulsion

261 kW - 1939 kW
(350 BHP - 2600 BHP)

Series 60

Engine model	Rated power ICFN			Application group		
	kW	bhp	rpm	1A	1B	1D
60	261	350	1800	■		
60	280	375	1800	■		
60	298	400	1800	■		
60	317	425	1800	■		
60	336	450	1800	■		
60	354	475	1800	■		
60	354	475	2100		■	
60	373	500	1800	■		
60	399	535	2100		■	
60	447	600	2100		■	
60	466	625	2300			
60	499	670	2300			
60	552	740	2300			
60	597	800	2300			
60	615	825	2300			

Series 2000

8V 2000 M72	720	966	2250		■	
8V 2000 M84	810	1085	2450			■
8V 2000 M84L	895	1200	2450			■
10V 2000 M72	900	1205	2250		■	
8V 2000 M94	932	1250	2450			
10V 2000 M86	1015	1360	2450			■
12V 2000 M72	1080	1450	2250		■	
10V 2000 M96	1120	1500	2450			
10V 2000 M96L	1193	1600	2450			
12V 2000 M86	1268	1700	2450			■
12V 2000 M96	1342	1800	2450			
12V 2000 M96L	1432	1920	2450			
16V 2000 M72	1440	1930	2250		■	
12V 2000 M96X**	1472	2002**	2450			
16V 2000 M86	1630	2186	2450			■
16V 2000 M96	1790	2400	2450			
16V 2000 M96L	1939	2600	2450			

* emission stage has been superseded, local exemptions may apply

** For the 12V2000M96X power rating = mhp

Applic. group	Fuel consump. at rated power		Optim.	Emissions Optimization			
	g/kWh	l/h		g/kWh	IMO	EPA	EU
1DS	206	65	REQ.	II	T2c*	-	-
	205	69	REQ.	II	T2c*	-	-
	198	71	REQ.	II	T2c*	-	-
	197	75	REQ.	II	T2c*	-	-
	196	80	REQ.	II	T2c*	-	-
	196	84	REQ.	II	T2c*	-	-
	203	87	REQ.	II	T2c*	-	-
	196	88	REQ.	II	T2c*	-	-
	205	98	REQ.	II	T2c*	-	-
	210	113	REQ.	II	T2c*	-	-
■	216	121	REQ.	II	T2c*	-	-
■	211	127	REQ.	II	T2c*	-	-
■	215	143	REQ.	II	T2c*	-	-
■	218	157	REQ.	II	T2c*	-	-
■	219	162	REQ.	II	T2c*	-	-
	212	184	195	II	T2c*	IIIA	C1M
	218	213	192	II	T2c*	CCNR II	C1M
	227	245	194	II	T2c*	-	C1M
	215	233	197	II	T2c*	IIIA	C1M
■	226	254	195	II	T2c*	CCNR II	C1M
	219	268	192	II	T3r	RCD 2	-
	208	271	195	II	T2c*	IIIA	C1M
■	220	297	192	II	T3r	RCD 2	-
■	223	320	192	II	T3r	RCD 2	-
	214	326	196	II	T3r	RCD 2	-
■	215	347	195	II	T3r	RCD 2	-
■	216	373	193	II	T3r	RCD 2	-
	206	357	195	II	T2c*	IIIA	C1M
■	218	387	194	II	T3r	RCD 2	-
	217	426	193	II	T3r	RCD 2	-
■	215	463	190	II	T3r	RCD 2	-
■	216	505	190	II	T3r	RCD 2	-

Diesel/gas engines for mechanic propulsion

746 KW - 2000 KW
(1000 BHP - 2688 BHP)

Series 4000

Engine model	Rated power ICFN			Application group		
	kW	bhp	rpm	1A	1B	1D
8V 4000 M53R	746	1000	1600	■		
8V 4000 M55RN ^g	746	1000	1600	■		
8V 4000 M54R	746	1000	1600	■		
8V 4000 M54	895	1199	1800	■		
8V 4000 M53	920	1234	1800	■		
8V 4000 M63	1000	1340	1800	■		
12V 4000 M53R	1140	1529	1600	■		
12V 4000 M54	1193	1600	1800	■		
12V 4000 M53	1380	1851	1800	■		
12V 4000 M64	1398	1875	1800	■		
12V 4000 M65R	1492	2001	1600	■		
16V 4000 M55RN ^g	1492	2001	1600	■		
12V 4000 M63	1500	2016	1800	■		
16V 4000 M53R [#]	1520	2038	1600	■		
16V 4000 M54	1685	2260	1800	■		
16V 4000 M53	1840	2473	1800	■		
12V 4000 M65L	1920	2575	1800	■		
16V 4000 M63R [*]	1920	2575	1600	■		
12V 4000 M73	1920	2575	1970		■	
16V 4000 M64	1999	2681	1800	■		
16V 4000 M63	2000	2688	1800	■		

1492 with 1600 rpm available on request

* 1840 kW with 1600 rpm available on request

G = Gas engine

Applic. group	Fuel consump. at rated power		Optim.	Emissions Optimization			
	g/kWh	l/h		g/kWh	IMO	EPA	EU
1DS	206	185	196	II	T2c*	IIIA	-
	REQ.	REQ.	REQ.	III	-	-	-
	206	185	196	II	T3c	-	-
	212	228	196	II	T3c	-	-
	208	231	192	II	T2c*	IIIA	-
	209	252	189	II/III	T2c*	IIIA	-
	201	276	200	II	T2c*	IIIA	-
	209	300	REQ.	II	T3c*	-	-
	201	334	196	II	T2c*	IIIA	-
	211	355	REQ.	II	T3c*	-	-
	194	REQ.	190	II/III**	T4***	-	-
	REQ.	REQ.	REQ.	III	-	-	-
	201	363	196	II	T2c*	IIIA	C1M
	199	364	198	II	T2c*	IIIA	-
	206	417	195	II	T3c*	-	-
	199	441	198	II	T2c*	IIIA	C1M
	REQ.	REQ.	REQ.	II/III**	T4c***	-	-
	203	468	203	II	-	-	-
	212	490	210	II	T2c*	-	-
	202	485	194	II	T3c*	-	-
	199	480	192	II	T2c*	IIIA	C1M

* emission stage has been superseded, local exemptions may apply

** fuel consumption values for IMO II/III on request

*** fuel consumption values for EPA T4/4c on request

Diesel/gas engines for mechanic propulsion

2124 KW - 10000 KW
(2848 BHP - 13410 BHP)

Series 4000

Engine model	Rated power ICFN			Application group		
	kW	bhp	rpm	1A	1B	1D
12V 4000 M73L	2160	2895	2050		■	
16V 4000 M65	2240	3004	1800	■		
16V 4000 M63L	2240	3004	1800	■		
12V 4000 M93	2340	3145	2100			
16V 4000 M73	2560	3441	1970		■	
16V 4000 M65L	2560	3433	1800	■		
12V 4000 M93L	2580	3460	2100			
16V 4000 M73L	2832	3798	2050		■	
16V 4000 M73L	2880	3860	2050		■	
16V 4000 M93	3120	4185	2100			
20V 4000 M65L	3200	4291	1800	■		
20V 4000 M73	3200	4291	1970		■	
16V 4000 M93L	3440	4615	2100			
20V 4000 M73L	3540	4747	2050		■	
20V 4000 M73L	3600	4830	2050		■	
20V 4000 M93	3900	5242	2100			
20V 4000 M93L	4300	5780	2100			

Series 1163

16V 1163 M74	4800	6437	1250		■	
16V 1163 M84	5200	6975	1280			■
16V 1163 M94	5920	7940	1325			
20V 1163 M74	6000	8045	1250		■	
20V 1163 M84	6500	8715	1280			■
20V 1163 M94	7400	9925	1325			

Series 8000

16V 8000 M71L	7280	9762	1150		■	
16V 8000 M91L	8000	10728	1150			■
20V 8000 M71	8200	10995	1150		■	
20V 8000 M71L	9100	12205	1150		■	
20V 8000 M91L	10000	13410	1150			

G = Gas engine

Mechanic propulsion

Applic. group	Fuel consump. at rated power		Optim.	Emissions Optimization			
	g/kWh	l/h		g/kWh	IMO	EPA	EU
1DS	213	554	210	II	T2c*	-	-
	202	545	193	II	-	-	-
	195	526	194	II	T2c*	IIIA	-
■	216	609	205	II	T2c*	-	C1M
	218	672	205	II	T2c*	-	C1M
	199	614	188	II/III**	T4	-	-
■	217	675	205	II	T2c*	-	-
	REQ.	REQ.	REQ.	II/III**	-	-	-
	220	763	205	II	T2c*	-	C1M
■	224	842	205	II/III**	T2c*	-	-
	REQ.	REQ.	REQ.	II/III	-	-	-
	213	821	210	II	T2c*	-	-
■	230	953	205	II	T2c*	-	-
	REQ.	REQ.	REQ.	II/III**	-	-	-
	212	920	210	II	T2c*	-	-
■	212	996	205	II/III	T2c*	-	C1M
■	220	1140	210	II	T2c*	-	C1M
	210	1214	202	II	-	-	-
	207	1297	200	II	-	-	-
■	212	1512	201	II	-	-	-
	208	1504	195	II	-	-	-
	208	1629	195	II	-	-	-
■	210	1872	195	II	-	-	-
	196	1719	188	II	T2c*	-	-
	198	1908	-	II	-	-	-
	190	1877	184	II	T2c*	-	-
	196	2149	185	II	T2c*	-	-
■	199	2398	192	II	-	-	-

* emission stage has been superseded, local exemptions may apply

** fuel consumption values for IMO III on request

*** fuel consumption values for EPA T4c on request



ENGINES AND GENSETS FOR ON-BOARD POWER GENERATION AND ELECTRIC PROPULSION



Engines and gensets for on-board power generation and electric propulsion – 50 Hz @ 1500 rpm

271 KW - 2600 KW
(363 BHP - 3487 BHP)

Series 60

Engine model	Rated power ICXN		Genset model	Rated power	
	kW	bhp		kWe	kVA
60	271	363	–		
60	322	432	–		

Series 4000

8V 4000 M23F	760	1019	MG08V4000M23F	720	900
8V 4000 M33F	880	1181	MG08V4000M33F	830	1037
12V 4000 M23F	1140	1529	MG12V4000M23F	1080	1350
12V 4000 M33F	1320	1774	MG12V4000M33F	1260	1575
12V 4000 P63	1350	1810	■		
16V 4000 M23F	1520	2038	MG16V4000M23F	1460	1825
12V 4000 P63	1560	2092	■		
12V 4000 M35F	1560	2092	REQ.	REQ.	REQ.
16V 4000 M33F	1760	2366	MG16V4000M33F	1690	2112
16V 4000 P63	1800	2414	■		
16V 4000 P63	2080	2789	■		
20V 4000 P63	2245	3011	■		
20V 4000 P63	2600	3487	■		

* emission stage has been superseded, local exemptions may apply

** fuel consumption values for IMO III on request

■ on request

Applic. group	Fuel consump. at 75%				at 100%		Emissions Optimization		
	3A	3B	g/kWh	l/h	g/kWh	l/h	IMO	EPA	CIM
■			199	54	200	72	I*	–	
	■		197	63	195	83	I*	–	
		■	216	148	207	189	II	–	
		■	211	167	205	217	II	–	
■			211	217	200	274	II	–	
		■	205	244	197	312	II	–	CIM
■			204	248	204	331	II	–	
■			210	287	201	367	II	–	
		■	202	284	202	378	II	–	
		■	REQ.	REQ.	REQ.	REQ.	II	–	
		■	205	325	199	420	II	–	CIM
■			201	326	198	428	II	–	
		■	199	373	197	492	II	–	
■			210	425	207	558	II	–	
		■	206	482	211	659	II	–	

Engines and gensets for on-board power generation and electric propulsion – 60 Hz @ 1800 rpm

271 KW - 3200 KW
(363 BHP - 4291 BHP)

Series 60

Engine model	Rated power ICXN		Genset model	Rated power	
	kW	bhp		kWe	kVA
60	271	363	–		
60	322	432	–		
60	322	432	–		
60	370	496	–		

Series 4000

8V 4000 M24S	895	1200	MG08V4000M24S	850	1062
8V 4000 M23S	920	1234	MG08V4000M23S	870	1090
8V 4000 M33S	1040	1395	MG08V4000M33S	990	1237
12V 4000 M24S	1193	1600	MG12V4000M24S	1140	1425
12V 4000 M23S	1380	1855	MG12V4000M23S	1310	1638
12V 4000 M34S	1398	1875	MG12V4000M34S	1340	1675
12V 4000 P83	1455	1951	■	1385	1825
12V 4000 M33S	1560	2097	MG12V4000M33S	1480	1850
12V 4000 M53B	1650	2213	■	REQ.	REQ.
12V 4000 P83	1680	2253	■	1600	2112
16V 4000 M24S	1685	2260	MG16V4000M24S	1620	2025
16V 4000 M23S	1840	2473	MG16V4000M23S	1750	2188
16V 4000 P83	1940	2602	■		
16V 4000 M34S	1999	2681	MG16V4000M34S	1920	2400
16V 4000 M33S	2080	2796	MG16V4000M33S	1990	2488
16V 4000 M53B	2200	2950	■		
16V 4000 M25S	2240	3004	REQ.	REQ.	REQ.
16V 4000 M43S	2240	3004	MG16V4000M43S	2150	2688
16V 4000 P83	2240	3004	■		
20V 4000 P83	2425	3252	■		
16V 4000 M35S	2560	3433	REQ.	REQ.	REQ.
20V 4000 P83	2800	3755	■		
20V 4000 M53B	3015	4043	■		
20V 4000 M35S	3200	4291	REQ.	REQ.	REQ.

* emission stage has been superseded, local exemptions may apply

** fuel consumption values for IMO II on request

■ on request

Applic. group	Fuel consump.				Emissions Optimization			
	at 75%		at 100%		IMO	EPA	C1M	
3A	3B	g/kWh	l/h	g/kWh	l/h			
■		200	49	197	64	II	T2c*	-
■		200	58	197	76	II	T2c*	-
	■	196	57	197	76	II	T2c*	-
	■	196	65	200	89	II	T2c*	-
■		219	176	215	231	II	T3c	-
■		221	183	211	233	II	T2c*	-
	■	218	204	210	262	II	T2c*	-
■		221	237	208	298	II	T3c*	-
■		215	267	205	340	II	T2c*	C1M
	■	223	499	210	352	II	T3c*	-
■		211	276	203	355	II	T1NRMM*	-
	■	210	295	206	386	II	T2c*	C1M
■		215	319	211	418	II	-	-
	■	207	313	207	418	II	T1NRMM*	-
■		REQ.	REQ.	REQ.	REQ.	II	T3c*	-
■		214	355	207	457	II	T2c*	C1M
■		211	369	205	477	II	T1NRMM*	-
	■	228	410	202	484	II	T3c*	-
■		209	393	203	509	II	T2c*	C1M
	■	208	414	208	551	II	-	-
■		REQ.	REQ.	REQ.	REQ.	II**	-	-
	■	208	421	203	548	II	T2c*	-
	■	205	413	204	549	II	T1NRMM*	-
■		211	461	209	608	II	T1NRMM*	-
	■	REQ.	REQ.	REQ.	REQ.	II**	-	-
	■	209	527	215	723	II	-	-
	■	214	583	204	741	II/III	-	-
	■	REQ.	REQ.	REQ.	REQ.	II/III	-	-

ENGINES AND GENSETS FOR EXPLORATION AND PRODUCTION



Photo: Øyvind Hagen/Stattli



Engines and gensets for offshore power generation –
50 Hz @ 1500 rpm

1350 KW - 2600 KW
(1810 BHP - 3487 BHP)

Series 4000

Engine model	Rated power ICXN		Genset	Rated power	
	kW	bhp		kWe	kVA
12V 4000 P63	1350	1810	PP12V4000P63	1295	1620
12V 4000 P63	1560	2092	PP12V4000P63	1500	1875
16V 4000 P63	1800	2414	PP16V4000P63	1730	2160
16V 4000 P63	2080	2789	PP16V4000P63	2000	2500
20V 4000 P63	2245	3011	PP20V4000P63	2155	2695
20V 4000 P63	2600	3487	PP20V4000P63	2500	3120

* emission stage has been superseded, local exemptions may apply
■ on request

Application group	Fuel consump.				Emissions Optimization			
	at 75%		at 100%		IMO	EPA		
3A	3B	3C	g/kWh	l/h	g/kWh	l/h		
■			204	248	204	331	II	-
	■	■	202	284	202	378	II	-
■			201	326	198	428	II	-
	■	■	199	373	197	492	II	-
■			210	425	207	558	II	-
	■	■	206	482	211	659	II	-

Engines and gensets for offshore power generation –
60 Hz @ 1800 rpm

1455 KW - 2800 KW
(1951 BHP - 3755 BHP)

Series 4000

Engine model	Rated power ICXN		Genset	Rated power	
	kW	bhp		kWe	kVA
12V 4000 P83	1455	1951	PP12V4000P83	1395	1745
12V 4000 P83	1680	2253	PP12V4000P83	1615	2015
16V 4000 P83	1940	2602	PP16V4000P83	1860	2330
16V 4000 P83	2240	3004	PP16V4000P83	2150	2690
20V 4000 P83	2425	3252	PP20V4000P83	2330	2910
20V 4000 P83	2800	3755	PP20V4000P83	2690	3360

* emission stage has been superseded, local exemptions may apply
■ on request

Application group			Fuel consump.				Emissions Optimization	
3A	3B	3C	at 75%		at 100%		IMO	EPA
			g/kWh	l/h	g/kWh	l/h		
■			211	276	203	355	II	T2NRMM*
	■	■	207	313	207	418	II	T2NRMM*
■			211	369	205	477	II	T2NRMM*
	■	■	205	413	204	549	II	T2NRMM*
■			211	461	209	608	II	T2NRMM*
	■	■	209	527	215	723	II	T2NRMM*

EMISSION REDUCTION TECHNOLOGIES



Emission reduction technologies

SCR SOLUTION

SCR solution

As installation space is always restricted inside the engine room, the inhouse developed airless SCR (Selective Catalytic Reduction) solution from **mtu** is compact and maintenance friendly. The system is designed and optimized for easy integration, and additional space to fit the exhaust gas aftertreatment is reduced to a bare minimum. Amonia slip is prevented under all operating conditions by a closed loop regulated control system. Besides the exhaust emissions related features, our SCR system also reduces noise.

SCR - the ideal solution for the marine world

When using EGR (Exhaust Gas Recirculation) technology, the quality of the fuel is essential. Fuel with more than 15 ppm sulfur will lead to the formation of sulfur acid in the EGR cooling process. Sulfur acid will cause substantial engine failures over time. As many vessels operate worldwide, especially in the offshore service and supply business, we evaluate SCR as the preferred solution to maintain reliability of our engines and the safety of your vessel and crew. SCR technology allows operation with lower fuel quality. Developing all major key technologies inhouse like, SCR, EGR, turbocharging and common rail fuel injection, means we are able to shape the ideal solution to meet IMO III and EPA Tier 4 emissions regulations. At **mtu** we treat EGR as the ideal solution for applications like mining or oil&gas onshore, but within the marine world we are convinced that SCR technology grants much higher availability and component lifetime.

SCR cubical-box for high-power application**Generator set with SCR flat-box**

Emission reduction technologies

A LONGTIME PROVEN MARINE ENGINE -
THE NEW SERIES 4000 M05.

More than 20 years ago, in 1996 the first Series 4000 marine engine was presented at SMM exhibition in Hamburg. Since then, the Series 4000 is trusted in numerous applications.

With more than 50,000 Series 4000 engines sold worldwide we gained experience from more than 250,000,000 operating hours which were directly fed into the development of the next generation of our marine workhorses. As an expert for tough applications like mining, oil&gas, rail and marine, we were always ready to go the next step - ahead of everyone else.

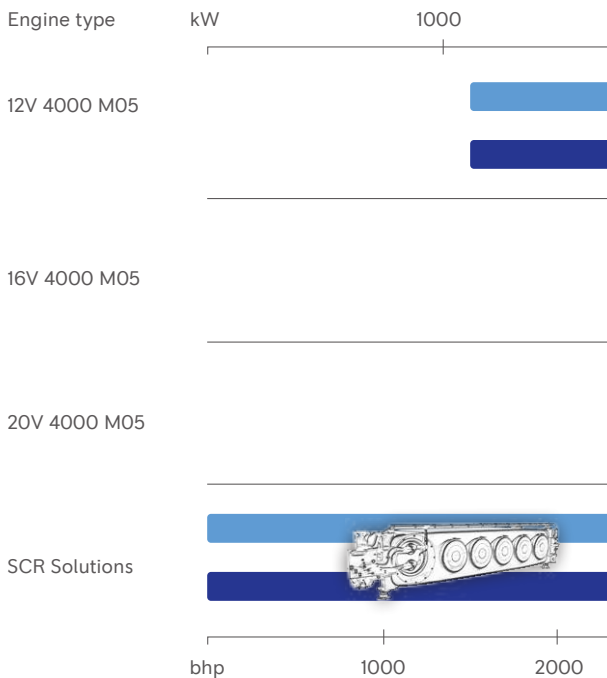

This is just as true today, as it was in 1996 when we introduced the first high speed diesel engine with common rail fuel injection. In 2016 we will be presenting the only high-speed diesel engine for tough workboat applications capable of up to 3200 kW (4291 bhp).

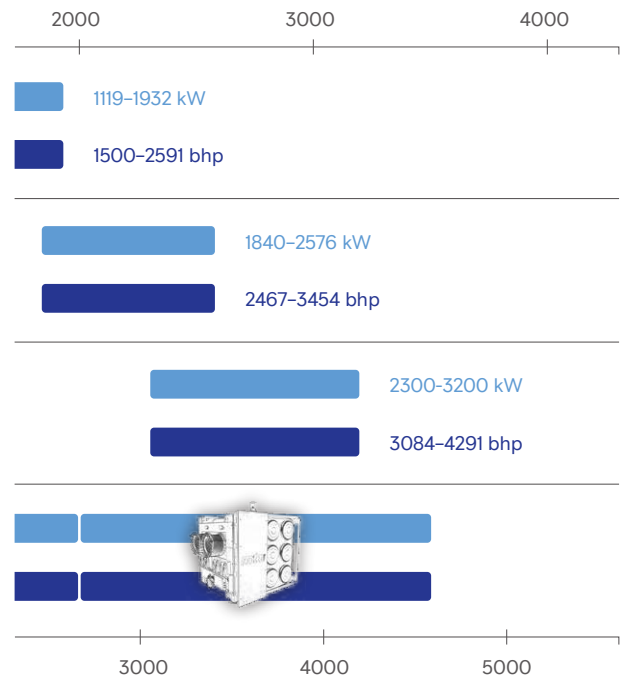

SYSTEMS SOLUTIONS



Systems solutions

SYSTEM EXPERTISE

We are one of the world's leading manufacturers of propulsion and power generation systems for marine applications:

mtu products are used on all the world's oceans and in all marine areas.

For us, being a systems supplier means taking complete care of our customer's needs at any point of the life cycle.

Our key technologies in diesel engine development and manufacturing comprising:

- Turbo charging units
- Fuel injection systems
- Engine management systems
- Automation systems

The key technologies are completed by validated and proven accessories like:

- Fuel treatment and filtration units
- Resilient engine mounts
- Resilient- and offset compensating couplings
- Gearboxes
- Exhaust silencers

Noise reduction technology

Double resilient mounting systems and active mounting systems are available for applications with the highest acoustic demands, such as comfort yachts or research vessels.

Emissions reduction technology

In addition to low emission diesel engines, we offer exhaust after treatment systems to meet the most stringent emissions requirements.

- Selective catalytic reduction (SCR) units:
 - Reduction of NOx emissions of diesel engines
 - Enables customers to achieve IMO Tier III emission levels with current Tier II engines.
- Diesel particulate filters (DPF):

The new **mtu** engine generations, especially of the Series 2000 & 4000 are exceeding emission regulation limits and are optimized to reduce soot also during transient operation.

Therefore particulate filters (DPF) are requested for special applications only:

- Active filter regeneration via burner
- Enabled for low load operation
- Optimum in system reliability
- PM-reduction up to 99 %
- Class certified: LR, GL

Gas-protected operation

In order to maintain a high level of safety in dangerous, explosive environments, some engines of the 4000 and 8000 Series can be equipped for gas protection around flammable or explosive gases. Engines are equipped with a safety package that meets with the related operational conditions.

For further information, please contact your distributor or visit www.mtu-solutions.com/contact

Systems solutions

COMBINED PROPULSION SYSTEMS

Our engineering expertise and operating experience covers a large range of combined propulsion systems, such as:

- Combined Diesel and Diesel (CODAD)
- Combined Diesel and/or Gas Turbine (CODAG, CODOG)
- Combined Diesel-Electric and Gas Turbine (CODELAG)
- E-Drive Systems - Combined Diesel and/or Electric or Hybrid

The intelligent combination of diesel engines, electric motors, gas turbines and batteries allows optimal adaptation of the propulsion system to the various operational requirements.

In order to reduce emissions and operating costs, combined systems e.g. diesel-electric propulsion systems are the preferred solution: The mechanical energy produced by the diesel engine is converted into electricity using a generator and then transmitted to the electric motors driving the ship's propellers.

By adding battery modules for energy storage we can also provide cutting edge hybrid propulsion systems.

On request, we will serve as the general contractor, taking complete technical and commercial responsibility for the entire propulsion and power generation system as well as the automation system. From project engineering and project management to support and service, we are your single source partner for complete solutions.



Application example of complete propulsion system



All systems can drive various kinds of propulsors, e.g. FPP, CPP, WJ, Voith Schneider, also in combination with CODAD, CODOG, CODAG, CODELAG or E-Drive propulsion systems.

Systems solutions

STANDARDIZED AND SYSTEM
SOLUTIONS GENOLINE|
GENOLINE NEW GENERATION (NG)

Genoline|Genoline NG is an **mtu** non-classified and classified automation system for on-board power generation plants. The modular system design guarantees optimum adaptation of the diesel engine and generator to the diversity of operating conditions for the on board power generation. It is available for **mtu** Series 4000 engines.

genoline offers the following applications

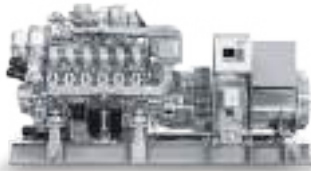

**On-board
service power**
non-classified
and classified



**Diesel-electric
propulsion plant**
non-classified
and classified



**Special
applications**
- MIL
- Shock
- EMC etc.

Genoline|Genoline NG automation system is an innovative high-end developed system with LOP (Local Operating Panel).

Customer interfaces

Interfaces	I/O signals	Power supply	Power supply
MODBus RTU	(hardwired)	main and	230 - 440 VAC
MODBus TCP/IP - (only Genoline NG)	for monitoring and control	emergency (redundant)	(50/60 Hz)
J1939		24 VDC	
CANopen			

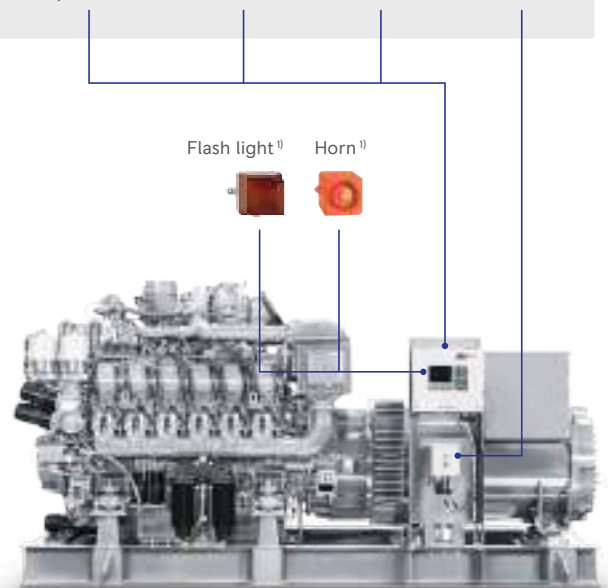

Priming pump and control¹⁾

1) Optional features

Systems solutions

MARINE GENSETS

Our gensets are based on Series 4000 engines. Whether you are looking for onboard power, diesel-electric or hybrid propulsion, our gensets meet the full spectrum of requirements.



Standardized commercial generator set shown with Series 4000



Our premium generator set. Here exemplarily shown with Series 4000

Our gensets are available as a constant speed version in 50 or 60 Hz or as a variable speed configuration with added electronics. Our gensets are tailored to the specific needs of each application. Whether you are looking for a standardized cost-effective commercial genset or high-end yacht gensets.

We also provide emergency gensets for critical situations at sea, when absolute reliability is essential. In addition to gensets for main propulsion and onboard power, we also supply lower-power gensets which can be installed as separate power units in the engine room.

Your benefits are:

- Gensets based on proven Series 4000 engines – of which over 90,000 have been sold worldwide
- Outstanding acoustic optimization for best-in-class comfort (noise and vibration levels can be contractually guaranteed, with all values proven on our test benches to minimize risk)
- Featuring special plug-and-play technology such as media plate and integrated piping for very easy installation
- All our gensets are classifiable according to e.g. DNV-GL, LRS
- Gensets with high quality finishing and painting dedicated for the yacht market

Systems solutions

OFFSHORE GENERATOR SETS

We offer complete solutions from a single supplier. All components are integrated, thoroughly tested and supported. Everything is designed to work together, which prolongs preventive maintenance and overhaul intervals. Decades of experience as an offshore specialist gives us the expertise and flexibility you need to keep your drilling operation productive and profitable.

Our offshore product range includes diesel engines and systems for:

- Generator sets for emergency, essential, auxiliary and main power
- Fire pump drivers for mechanical/hydraulic/ electric installations
- Mud pump drivers
- Wellserve power packs
- Nitrogen units
- Cranes
- Cement pumps
- Hydraulic power packs

We also offer customized offshore documentation according to project specific requirements.

Our systems solutions for offshore exploration & production applications



Engine plus system



Modularized generator drive



Standardized generator set



Automation systems - **mtu** SmartBridge

ONE PLATFORM. ONE DESIGN. ONE SOURCE.

Our **mtu** SmartBridge is a fully integrated bridge solution. Created in partnership with yacht specialists Team Italia, this outstanding ensemble raises overall ship performance, improves safety and offers a new level of customer experience.

One platform: Full integration

The navigation equipment and all the yacht subsystems necessary to monitor and control the entire vessel can be seamlessly integrated in one platform. There is no need to modify third-party equipment or subsystems integrated into **mtu** SmartBridge.

One design: Elegant, intuitive, user-optimized

All the information is presented in one elegant and user-optimized design.

- Total navigation control, simplified management
- Innovative design and functionality
- Safe and user-friendly thanks to consistent user interface
- Seamless user interface across all integrated subsystems

One source: Dependability for builders and owners

All the technology and services come from one source: **mtu**.

- One face to the customer for complete vessel operating system
- Global **mtu** service support, anytime, anywhere
- Seamless integration of product and technology
- Scalable, to integrate additional functions
- High flexibility for updates and upgrades

Automation systems

INTEGRATED SHIP AUTOMATION SYSTEM

mtu CALLOSUM

The integrated ship automation system **mtu** Callosum provides optimal solutions for all types and sizes of ships to comply various requirements.

mtu Callosum_MC – Monitoring and control system

mtu Callosum_MC monitors and controls the entire drive system, onboard power supply, general areas

- Visualization and control:
 - FPP/PPP/WJ/VS/POD/SDS/combined systems
 - Joystick control system
 - Dynamic positioning system
 - Integrated bridge system
 - Fire detection system
 - Duty alarm system
 - Machinery telegraph
 - CCTV system
 - Electrical power management system
 - Crew location system
 - Uninterruptible power supply
 - Consoles
 - Switchboards
 - Sensors
- Interfaces:
 - NET-DDE
 - OPC
 - NMEA0183
 - CANopen
 - Modbus



mtu Callosum_DC – Damage control system

mtu Callosum_DC ensures the precise localization of any type of damage caused by fire, flood, collision, grounding.



- Visualization:
 - 3-click technology
 - Static an/or dynamic automated kill cards
 - 3D isometric deck views
 - Plot function
 - Tailor made engineering
 - Situation management
 - Command state board
 - etc.

mtu Callosum_MT – Maintenance support system

mtu Callosum_MT provides support for the maintenance and upkeep onboard – 24 hours a day, 7 days a week.



- Visualization:
 - Corrective maintenance
 - Preventive maintenance
 - Condition based maintenance
 - Performance monitoring

mtu Callosum_TS – Onboard and land-based training system

mtu Callosum_TS allows training and further education of the crew during ship operation.



- Visualization:
 - Onboard training
 - Land-based training

Automation systems

STANDARDIZED PROPULSION
AUTOMATION SYSTEMS
BLUEVISION|NEWGENERATION

For many years, our sophisticated standard automation systems controlled, regulated and monitored the engine functions – always doing a perfect job!

BlueVision|**NewGeneration** automation solutions more convenient than ever before: easy to customize, easy to integrate, easy to operate.

BlueVision|**NewGeneration** is available in multiple versions to meeting different requirements according to boat design and customer budgets.

- straightforward non-classifiable version
BlueVision_Basic|**NewGeneration**
- cost effective classifiable version
BlueVision_Advanced|**NewGeneration**
- enhanced classifiable version
BlueVision_Avantgarde|**NewGeneration**

The modular system design allows a flexible configuration; intelligent data bus technology ensures reliable data exchange and reduces cable efforts. Optimized interfaces between the propulsion and automation systems result in ideal total solutions that guarantee you security, efficiency and reliability.

With BlueVision|**NewGeneration** we offer you a complete and convenient system solution individually optimized for your ship, as well as comprehensive service – all from one source.

Thanks to “plug & play”, the system is as easily installed as it is operated.

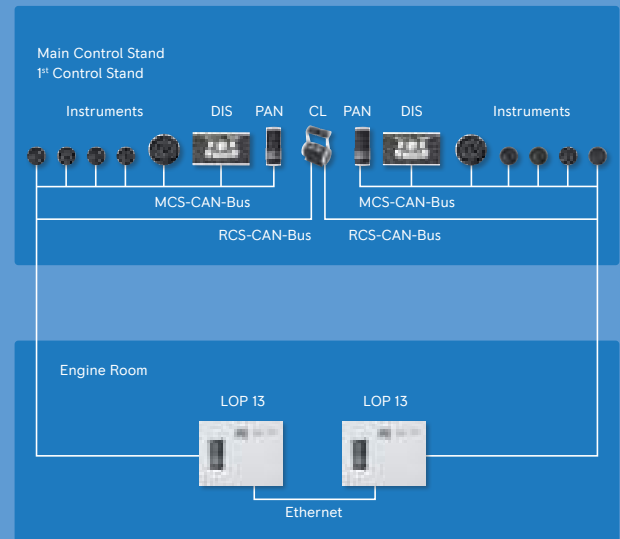
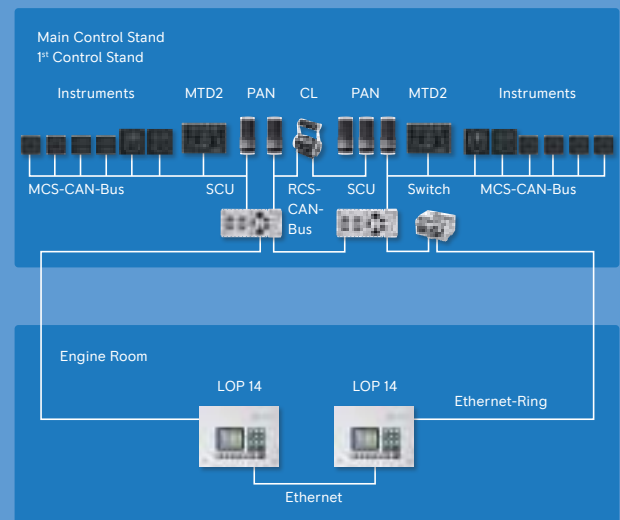
BlueVision_Basic|**NewGeneration**BlueVision_Advanced|**NewGeneration**

Automation systems

STANDARDIZED PROPULSION
AUTOMATION SYSTEMS
BLUEVISION|NEWGENERATION

Simple interfaces connect the monitoring & control system BlueVision|NewGeneration with the **mtu** diesel engine (via EIM) and the gearbox.

All components are type-approved und type-examination tested in shake/vibration/stress tests.

Customer benefits

BlueVision_Basic|NewGeneration and BlueVision_Avantgarde|NewGeneration are automation systems for propulsion plants in yachts and workboats with **mtu** Series 2000 or 4000 engines.

BlueVision|NewGeneration offers the following benefits:

- High operational availability and reliability of the propulsion plant
- High flexibility thanks to modular system structure and open architecture
- Classifiable system in line with current directives
- Quicker and easier commissioning via structured user dialogue
- Type-tested components
- Development in accordance with current standards
- Optimized operation and visualization of the propulsion plant
- Uniform spare part concept across all **mtu** Series
- Global sales and service network
- Self-learning “Improved Crash-Stop” in order to stop the ship as quickly as possible

Additional

- Available in different versions with a choice of HMI interfaces such as small touch displays but also comprehensive operator stations (with BVNG_Avantgarde|NewGeneration).

BlueVision_Avantgarde|NewGeneration

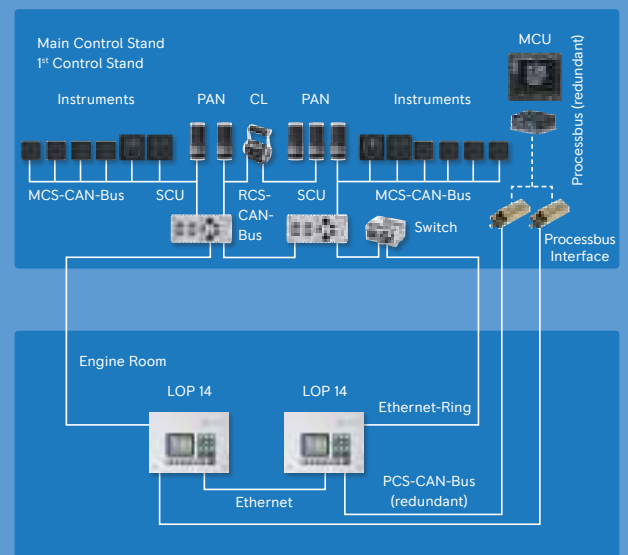
MTD2 (Multi Touch Display
2. Generation)LOP 14 (Local Operating
Panel)

Automation systems

BLUEVISION|NEWGENERATION
JOYSTICK CONTROL**Visionary simple. Simply visionary.**

As a system supplier, **mtu** not only provides you with the perfect yacht engine, but also with an automation system exactly adjusted to it. You get a complete package where everything is just right: not only powerful engine performance, but also maximum efficiency, uncompromising reliability and environmental compatibility.

With the new **mtu** Joystick System we introduce now a new system extension for the Remote Control System (RCS) of BlueVision|**NewGeneration**. The **mtu** Joystick System makes complex maneuvers more convenient than ever before and allows the captain to perform every maneuver just moving the joystick lever in the preferred direction.

Benefits

- Manoeuvrability in an easy and intuitive way
- Easy docking, anchoring and manoeuvring
- Controls vessel direction and speed including rotations
- Simultaneous engine, transmission and thruster control or thruster only
- Single or multi stations possible
- Wide range of compatible thruster units

**mtu** Joystick leverSTANDARDIZED PROPULSION
AUTOMATION SYSTEMS BLUEVISION

Perfectly balanced, standardized control and monitoring systems developed and manufactured inhouse, ensure that our proven marine propulsion technology functions exactly as you would expect it to. The integration of these cutting-edge automation systems provides optimum complete solutions which guarantee safety, efficiency and reliability. Without exception, we can always supply a complete system individually tailored to suit your vessel and backed up by a comprehensive service package – all from a single source.

bluevision Series 2000/4000

TFT color monitor

Propulsion control levers

System for

- Non-classified and classified applications
- FPP, CPP, WJ and VSP propulsion plants
- One to four engine propulsion plants

Options

- Extended to 6 control stands
- Printer
- Hand-held control unit

Explosive problem. Integral solution.

ATEX ZONE 2 (IIB T3 Gc)

Critical safety factors

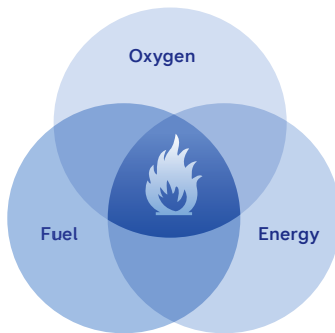

Modifications of P-engines for ATEX zone 2

The combination of three factors makes an explosion possible:

- Oxygen
- Fuel/flammable substance (gas, vapors, mist, or dust)
- Energy/ignition source (devices, electrical plants, sparks, hot surfaces)

The exclusion of one of these three factors means the elimination of the risk. In order to guarantee safety in potentially explosive environments, a modification of factor 3 – the engine – is the most efficient solution both technically and economically. **mtu** engines are designed to minimize or even prevent the risk of high surface temperatures and spark generation.

On request **mtu** P-engines fulfill the requirements of ATEX Zone 2: IIB T3 Gc according to directive 2014/34/EU. This means that they deliver an extremely high standard of safety in conjunction with superior cost efficiency.

Meaning of the ATEX marking.

- Zone 2:
An area in which an explosive mixture of gas is not likely to occur in normal operation and if it occurs it will exist only for a short time
- Explosion group IIB:
Explosive mixture of various types of gas, i.e. ethylene, whereas hydrogen and acetylene is excluded and air
- T3:
Surface temperature < 200°C
equivalent to class I division 2 (North America)
- Gc:
Equipment protection level (according to Zone 2 for gas hazard, former marking: 3G)

For further detailed explanation please refer to the ATEX directive.

Safety is good. Redundancy is better.

REDUNDANT CONTROLLER FOR FIRE PUMP DRIVE SYSTEMS (NFPA 20)

The NFPA-20 standard requires redundant engine controllers on fire-pump drive systems in order to prevent interruptions in the fire-pump water jet during an emergency. We are the first manufacturer in the world to offer redundant controllers for engines with common rail injection.

In accordance with this standard, the second controller must be installed on the engine and permanently wired. In the event of a fault on the first (main) controller, the second (backup) controller must take over the engine control automatically without interrupting the water jet. This measure increases the availability of your fire pumps and consequently the entire system.

The redundant controllers developed by us can be used in direct, hydraulic, and diesel-electric drive systems. To redundantly record all engine data required for controlling, a second sensor set is installed on the engine. The ECU7 engine control unit is used as a main and backup controller. Because the injectors and high-pressure fuel control block are not installed redundantly, triggering of these actuators must be switchable between the two controllers: and so the new SBX1 switch box forms the heart of this system.

Switching

The *mtu* engine controller offers the option of manual switching, whereby the controller active at any given moment is displayed optically (via LED). The switching process is designed to guarantee the greatest possible redundancy of the system. Optimal use is made of the ECU7 plugs for logic switching and for supplying the new unit. This results in extremely simple wiring. If switching is necessary, drops in speed and excessively high rail pressure must be prevented. Our system guarantees that these demands are met for all types of applications (direct, diesel-electric, or diesel-hydraulic pump drive), all engine cylinder variants (12V, 16V, or 20V), and for every engine base speed (1,500 rpm for 4000 P63 or 1,800 rpm for 4000 P83).

Benefits:

- Achieving the NFPA20 norm for Series 4000 P-engines
- Specifically designed for common rail injection
- Increased availability thanks to redundancy
- Simple retrofitting due to plug-and-play
- All components are developed to work together seamlessly
- All from one trusted source and in the quality you expect from us

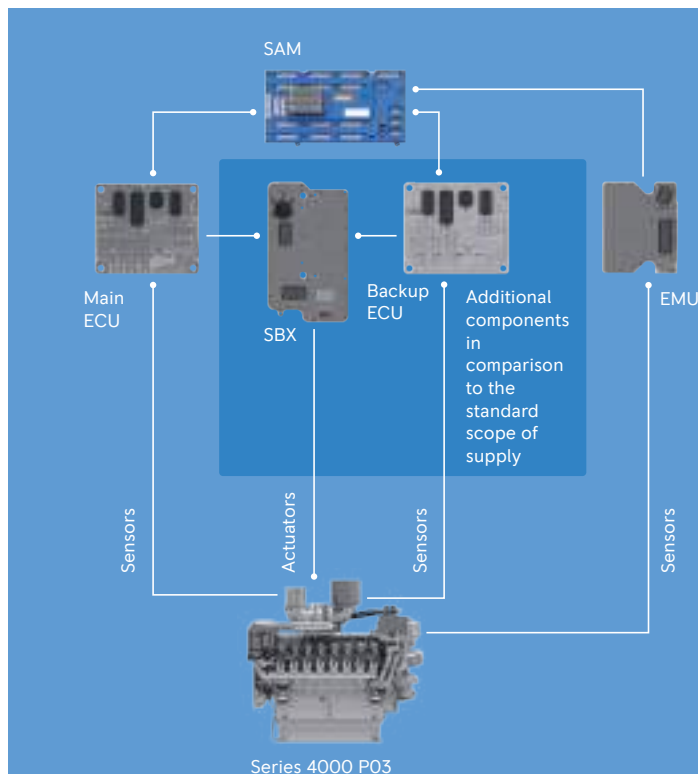

Digital solutions

HOW DIGITAL SOLUTIONS
OPTIMIZE YOUR BUSINESS.**Streamline your service requirements.**

We offer you the best possible service for your equipment by incorporating digitalization in a holistic approach. This helps improve our service to you and helps you operate your equipment more effectively.

Monitor and manage your equipment.

Our digital platform *mtu* Go! offers you the opportunity to analyze system data quickly, determine important action steps, and plan them optimally, either independently or together with our service department.

Maintain your data security.

We always adhere to the highest data privacy and security standards of our industry. Because we understand and value the trust you put in us by having us analyze your data to create the best possible service solutions for your equipment.

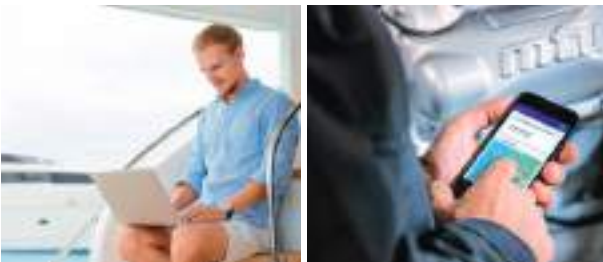

An onboard connectivity device transmits vital equipment data in near real-time to your screen.



Digital solutions

DELIVERING ACTIONABLE INSIGHTS
THROUGH DIGITAL SOLUTIONS.**Connect all your equipment**

Data collection from your fleet, asset, system and engine

Connectivity is the basis for all the advantages of digitally supported service. Using our edge software connected to the control unit, you and your service network can monitor relevant deviations from the optimum conditions remotely. We offer several ways to collecting data, including the creation of interfaces to already existing data sets. In doing so, we always adhere to the highest data privacy and security standards of our industry.

Access your data

- Remote monitoring, available for individual assets, as well as complete fleets worldwide
- Different device and software options ensure optimal connectivity
- Data privacy and security to the highest industry standards

**Monitor your fleet**

Visualization of data for a quick and accurate overview of your fleet

With the **mtu** Go! platform, predefined users, such as on-site technicians or managers, can view the system data and perform initial analyses by using diagnostic tools. By accessing the same information, your service network can provide fast support in handling alarms and planning necessary maintenance together with you. Open APIs allow you to interface directly to your existing dashboards or systems.

Keep track of your data

- All important data and alarms available at a glance for efficient fleet monitoring
- Intuitive and clear design for easy operation
- Visual comparison of data using the diagnostic tools for initial analyses

**Manage your fleet**

Digital solutions for your detailed data analysis on necessary actions

Supported by **mtu** Go! your Service Network is able to analyze all relevant data from your equipment and compare it with data sets from other systems. From this we together can proactively derive recommendations for action.

In future, the analysis can be enriched with additional external data sets, such as environmental influences or time schedules. Cross-linking data will create new opportunities for optimizing business processes.

Learn from your data (under development)

- Algorithms for proactive early detection of deviations
- Troubleshooting based on large amounts of data with artificial intelligence
- Comparison with data outside own fleet leads for faster knowledge transfer and optimum service tool for initial analyses

Complete lifecycle solutions

ENSURE A LONG, RELIABLE LIFE.

As your equipment ages, its needs – and yours – change. Our full portfolio of service solutions wrap around your investment, providing 360 degrees of customized support, for optimal value at every stage of life.

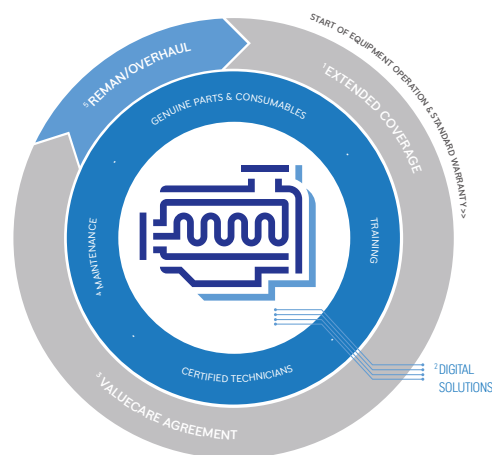

- 1 Avoid the unexpected with added protection beyond the standard warranty.
- 2 Make better decisions faster with digitally-enhanced tools.
- 3 Maximize availability and optimize lifecycle costs with a ValueCare Agreement.
- 4 Improve system performance and extend equipment life with on-demand support.
- 5 Keep a good thing going with factory reman/overhaul solutions.

Complete lifecycle solutions

RELY ON
OUR EXPERTISE.

To give your equipment a long and productive life, choose a partner you can trust. Only factory-certified technicians know how to get the job done right using proven service methods, factory-specified maintenance schedules and genuine OEM parts.

From preventive maintenance to complete overhaul, we are your true lifecycle partner. Whatever level of support you need, our global network of factory-trained professionals knows all about your equipment and is ready to help you maximize performance and minimize lifecycle costs.

Never compromise

mtu engines and systems are built to last with legendary high standards. When it's time for service, don't settle for anything less. Protect the life of your equipment with professional certified service technicians and genuine OEM parts and consumables – the only options that live up to our standards for craftsmanship, quality and performance. To get the most from your equipment, there are no shortcuts. For maximum reliability, performance and uptime, choose a name you can trust.

If you need us a little:

On-Demand Support—including professional inspections and preventive maintenance recommendations from us—helps you identify and address problems early, save on repairs or unexpected downtime, and optimize your equipment's performance and longevity. Inspections include visual assessment, test run and leak check, on-site oil and coolant analysis, diagnostic evaluation and reporting.

If you need us a lot:

ValueCare Agreements make it easy to keep your business running smoothly and reduce total cost of ownership by maximizing uptime, optimizing lifecycle costs and helping you avoid equipment-related business disruptions through preventive maintenance.

ValueCare

PLAN AHEAD

The annual cost of maintenance can vary dramatically depending on how and where your equipment is used. When optimal equipment availability and performance are essential, and predictable costs are preferred, Long-term Service Agreements can help.

Preventive

All preventive maintenance services up to 10 years according to your approved maintenance schedule, performed by **mtu**-certified technicians at your local **mtu**-authorized distributor.

All Inclusive

All preventive maintenance services up to 10 years according to your approved maintenance schedule, performed by **mtu**-certified technicians at your local **mtu**-authorized distributor, including all necessary corrective services.

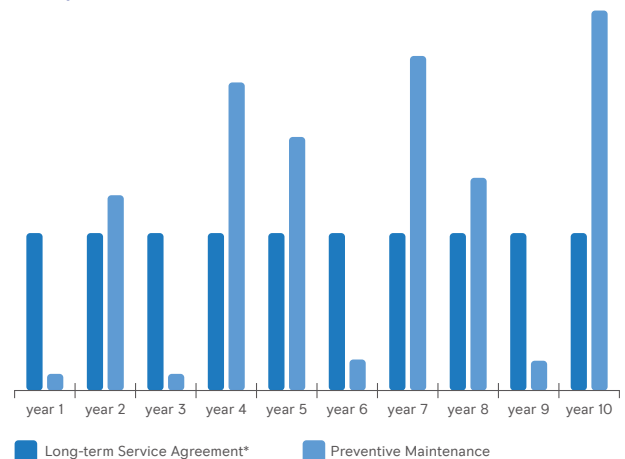
Example: Scheduled maintenance costs

ValueCare

PROTECT YOUR INVESTMENT

mtu engines — backed by Extended Coverage — provide invaluable peace of mind beyond the standard warranty. With Extended Coverage, you can be assured that the costs of unexpected repairs are covered, with service performed by **mtu**-certified technicians — upholding resale value and ensuring long-term confidence in your investment.

Extended Coverage protects you from the cost of unexpected repairs beyond your standard warranty, with professional service from **mtu**-certified technicians and coverage tailored to your needs. Packages can also be extended up to 5 years and are fully transferrable, enhancing resale value. Coverage includes material and labor for troubleshooting, fault clearance and corrective services to engines and on-engine electronics (excluding gearbox, alternators, or similar components). To ensure maximum quality, all repairs are conducted using only genuine **mtu** parts.

Extended Propulsion Coverage — an exclusive offering for pleasure craft — protects against the cost of unexpected repairs to your complete propulsion system beyond the standard warranty. The package is fully transferable, which enhances resale value. And with expert service performed worldwide by **mtu**-authorized service centers, you gain invaluable peace of mind.

Factory reman/overhaul solutions

KEEP A GOOD THING GOING



Your equipment was built to last, thanks to our legendary high engineering standards and unwavering commitment to service and support. And after a long and productive life, we provide options to help you go even further.

Exchange and save.

Factory Remanufactured Solutions involve replacing your existing engine and system with a remanufactured unit provided by your **mtu** service partner, and returning your original core for a credit. Utilizing the core exchange program minimizes downtime.

Turn back the clock.

Factory Overhaul Solutions involve the complete restoration of your original equipment. This solution is best for classic and specialized engines that lack the necessary population for a meaningful core exchange program or require a greater level of customization during the restoration and validation process, such as Series 183, 396, 493, 538, 595, 652, 956, 1163 and other engine Series (e.g. 2000 and 4000) on request.



Service network

LOCAL SUPPORT. WORLDWIDE.

The most important part of your power system isn't a part at all – it's your local service team. With more than 1,200 service locations worldwide – backed by regional Parts Logistics Centers in Europe, Asia and America – you can count on responsive support by expert technicians, wherever work takes you. To find your local service partner, visit www.mtu-solutions.com.



Always on call, 24/7

Whether it's connecting you with a local service partner or assigning an urgent problem to a dedicated team of our experts, we're ready to assist you—wherever you are, whatever you need.

Europe, Middle East, Africa +49 7541 90-77777

Asia/Pacific +65 6860 9669

North and Latin America +1 248 560 8888

info@ps.rolls-royce.com



EXHAUST EMISSIONS

Many countries have implemented environmental legislation to protect people from consequences of polluted air. For this reason an increasing number of countries regulate emissions from specific mobile and stationary sources. Emission standards may apply internationally, nationally and/or for specific areas. The enforcement of an emission legislation may depend for example on the area where the equipment is used and the way it is operated.

The emission legislations may be categorized by power range and/or cylinder capacity. Emission legislations generally require a certificate which states compliance. Stationary applications may require on-site approvals (on-site emission test) depending on the particular emission legislation.

Please find as follows examples of emission standards which apply to the marine industry. For details please consult the applicable legislation and/or permitting authority.

IMO - International Maritime Organization

MARPOL Annex VI Regulation 13 (NOx) and NOx Technical Code 2008: Marine diesel engines > 130 kW for ships engaged on international voyages to which MARPOL Annex VI applies (= flying the flag of a signatory, or entering waters of the jurisdiction of a signatory to the Annex. Signatory overview see IMO webpage, „Status of Conventions“). Fixed & floating platforms, including drilling rigs and similar structures, are considered as ships. For those structures IMO regulations are in addition to any controls imposed by the government which has jurisdiction over the waters in which they operate.

Applicability of tiers:

For new ships date of construction of the ship, for engine replacement with non-identical engine or installation of additional engine date of installation. Exemption rules are in place.

Currently applicable emission stages:

- IMO Tier II outside of NOx Emission Control Areas (NOx ECA)
- IMO Tier III is applicable in NOx Emission Control Areas (NOx ECA) only

Emission Control Areas (ECA):

- An ECA may limit NOx, SOx and particulate matter (PM) emissions, or both. MARPOL Annex VI Regulation 14 (SOx and PM emission compliance) requires fuels with less than 1000 ppm (0.1 %) sulphur (since January 1st, 2015).
- The enforcement dates of an ECA will be specified for each ECA individually. For the North American & US Caribbean ECA this has been January 1st, 2016 with regard to NOx.
- Additionally to the North American & US Caribbean the North Sea and the Baltic Sea are established as ECA for SOx and PM as well as NOx emissions.

We provide for IMO Tier III certified marine engines with SCR aftertreatment a NOx-conformity document, which is mandatory by IMO's 2017 SCR guidelines and the NOx technical code 2008.

EXHAUST EMISSIONS

US EPA - United States Environmental Protection Agency

40CFR1042: Marine diesel engines > 8 kW for vessels registered (flagged) in the United States.

Applicability of tiers:

Date of engine manufacture. Specific replacement engine rules are in place. Exemption rules are in place.

Currently applicable emission stages:

- < 600 kW EPA Tier 3
- < 1000 kW EPA Tier 3 - replaced by EPA Tier 4 latest by October 1st, 2017
- > 1000 kW EPA Tier 4
- > 600 kW EPA Tier 4 from October 1st, 2017
- Recreational engines: EPA Tier 3

EU - European Union: Commercial Marine

EU Regulation 2016/1628 has replaced the previously existing EU Nonroad Directives 97/68/EC amended by 2012/46/EC and the corresponding CCNR limits. defines, in addition to many other categories of off-highway engines, the requirements for engines used in inland waterway vessels. EU V applies for engines which have been placed into the market after 01/2019 respectively 01/2020 for engines > 300 kW.

EU - European Union: Recreational Marine

EU Recreational Craft Directive (RCD) 94/25/EC as amended by 2003/44/EC and replaced by 2013/53/EU from January 18th, 2016: propulsion engines for recreational crafts from 2.5 to 24 m hull length operating within EU territories.

Applicability of stages:

Date of placing the engine/boat into the market.
Exemption rules are in place.

Currently applicable emission stages:

- RCD 2

Additional to afore mentioned emission regulations we are able to deliver many engines also for regional emission standards such as BSO (Lake Constance) or SAV (Switzerland) on request.

Besides current emission standards we are able to deliver also replacement engines with outdated emission standards. Replacement engine rules need to be observed.

EXHAUST EMISSIONS

Samples for emission stages in marine industry:

IMO

IMO Seagoing ships

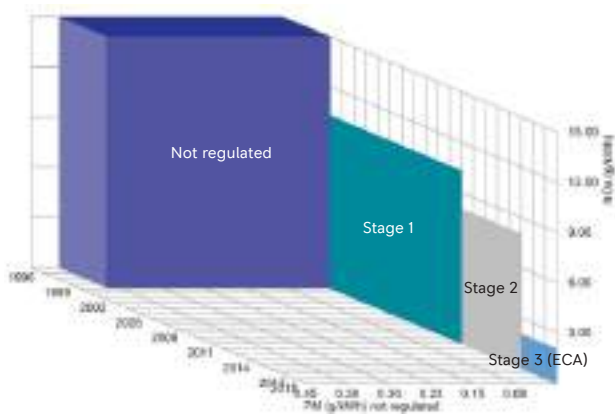

EPA

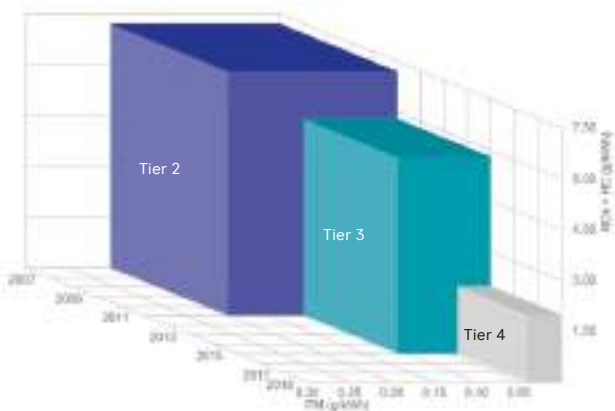

Abbreviations

T3c	EPA Tier 3 for commercial use
T3r	EPA Tier 3 solely for recreational use
T4c	EPA Tier 4 for commercial use
CCNR II	European commercial inland waterway transport - mutual recognition with EU IIIA
EU IIIA	European commercial inland waterway transport - mutual recognition with CCNR II
RCD 2	European recreational craft directive
IMO I	International Maritime Organization Stage I (beginning form January 2000)
IMO II	International emission standard outside of emission control areas (ECA)
IMO III	International emission standard within emission control areas (ECA)
T1NRMM	EPA Tier 1 - Nonroad Mobile Machinery
T2NRMM	EPA Tier 2 - Nonroad Mobile Machinery
EU V	EU Stage V as per (EU) 2016/1628

Please note

that the engines and systems (only) comply with country or region specific emission requirements and have appropriate emission certification(s) which are explicitly stated in respective technical specifications. Any Export/Import/Operation of the engine in countries or regions with different applicable emission law requirements is at the customers responsibility.



Stay posted with more powerful information
and follow **mtusolutions** under:



Rolls-Royce Group
www.mtu-solutions.com/marine

The Rolls-Royce name, Rolls-Royce badge and Rolls-Royce monogram
logos are registered Trade Marks of Rolls-Royce plc